

# ESPECIFICAÇÕES TÉCNICAS



## ZYPHO iZi LINEAR DRAIN

Zypho® iZi Linear Drain é uma solução para duche de pavimento com modernas calhas lineares de duche, de elevada qualidade e com sifão Geberit, prevenindo que os odores saiam devido aos 50mm guarda de água. Propriedades inovadoras, como capacidade de filtragem extra + pés ajustáveis + serpentina de parede dupla, de acordo com EN1717 + melhoria no conforto na montagem e limpeza, garantem segurança absoluta à instalação, tanto para o instalador como para o utilizador.



Fácil de instalar



Anti-Legionela



Fácil de limpar



Até 40% eficiência energética



Filtros de elevada performance



5 anos garantia



Sem baterias  
Sem eletricidade  
Sem cabos



Mais de 15 000 instalações no mundo inteiro

LINEAR DRAIN  
**izi**  
**30**  
HIGH FLOW  
REF ZYIZ30D10L7/8/9

LINEAR DRAIN  
**izi**  
**40**  
ECO SHOWER  
REF ZYIZ40D10L7/8/9



## ESPECIFICAÇÕES TÉCNICAS

LINEAR DRAIN  
**izi**  
**30**  
HIGH FLOW  
REF ZYI230D10L7/8/9

LINEAR DRAIN  
**izi**  
**40**  
ECO SHOWER  
REF ZYI240D10L7/8/9

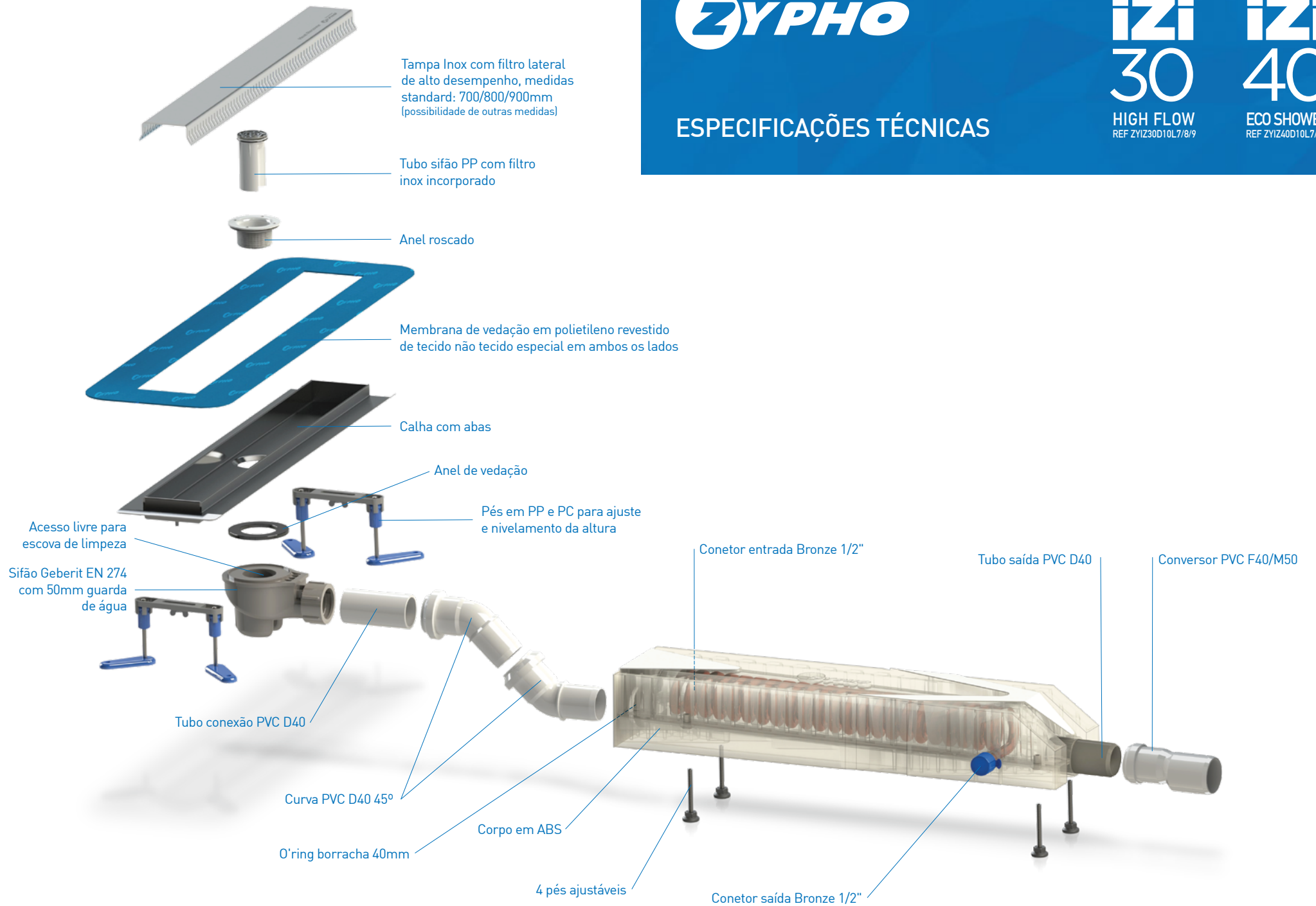



## DESENHO TÉCNICO

LINEAR DRAIN  
**izi**  
**30**  
HIGH FLOW  
REF ZYI230D10L7/8/9

LINEAR DRAIN  
**izi**  
**40**  
ECO SHOWER  
REF ZYI240D10L7/8/9

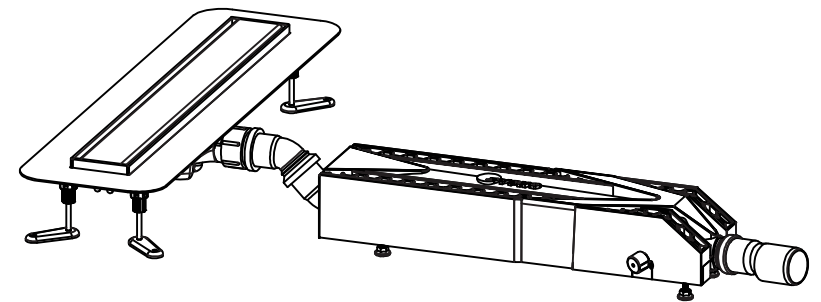
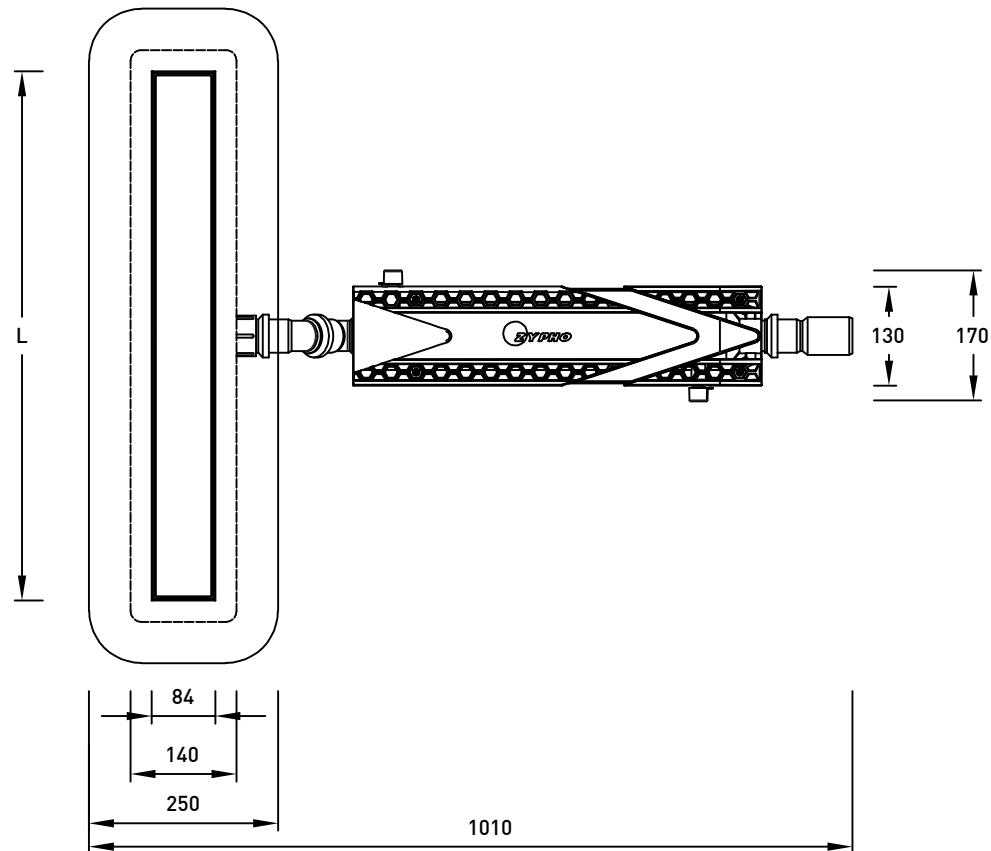
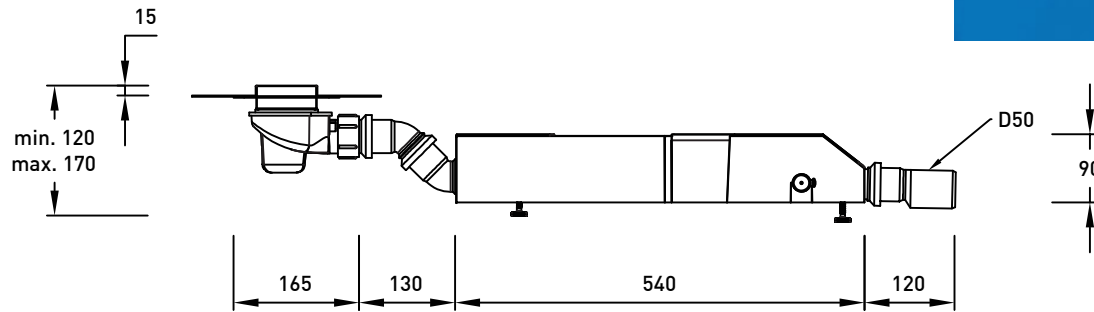

	EMPRESA	Zypho, S.A.			
DESCRIÇÃO		Desenho técnico			
PROJETO		Zypho iZi Linear Drain		DESIGNER J. Meliço	
DATA	TOLERÂNCIA	ESCALA	UNIDADES	VERSÃO	
20/04/20	+/- 2%	1:10	mm	MG_DTEN0420V1	